

3-PC SPRING VERTICAL CHECK VALVE

三片式立式止回阀

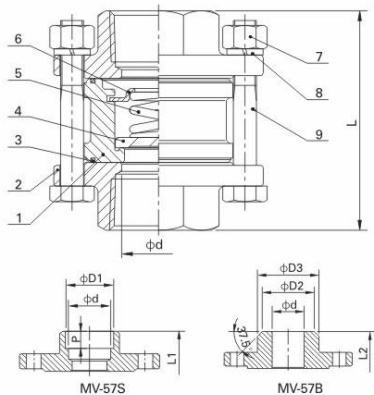

MV-57 (NEW)

- 螺纹标准: ISO, BS, DIN, JIS, ASME
 - 密封: 金属硬密封
 - 压力等级: 1000PSI (PN63)
 - 工作温度: $-25^{\circ}\text{C} \sim +180^{\circ}\text{C}$
 - 材料: CF8M, CF8, CF3M, WCB
-
- Investment casting for body, cap
 - Threaded: ISO, BS, DIN, JIS, ASME
 - Seal: Metal-to-metal
 - Pressure rating: 1000PSI(PN63)
 - Working temperature: $-25^{\circ}\text{C} \sim +180^{\circ}\text{C}$
 - Material: CF8M, CF8, CF3M, WCB

MATERIAL LIST

ITEM	PART	MATERIAL	QTY.
1	Body	CF8M	1
2	Cap	CF8M	2
3	Seal	PTEE	2
4	Disc	CF8M	1
5	Spring	SS316	1
6	Stopper	SS304	1
7	Nut	SS304	4(6)
8	Washer	SS304	4(6)
9	Bolt	SS304	4(6)

DIMENSION LIST

SIZE	d	L	L1	D1	P	L2	D2	D3
1/4"	11	49	49	14.1	10	45	13	18
3/8"	12.5	49	49	17.1	10	45	13	18
1/2"	15	56	56	21.7	10	56	17	22
3/4"	20	65	65	27.1	14	65	22	27
1"	25	74	74	33.8	14	74	28	34
1-1/4"	32	83	83	42.5	15	83	35	43
1-1/2"	40	91	91	48.6	15	91	43	49
2"	50	110	110	61.1	19	110	54	61
2-1/2"	65	126	126	73.8	21	126	70	76
3"	80	141	141	89.8	24	141	85	93
4"	100	162	162	115.2	24	162	105	116

PRESSURE-TEMPERATURE RATING

