

3-PC BALL VALVE

三片式球阀

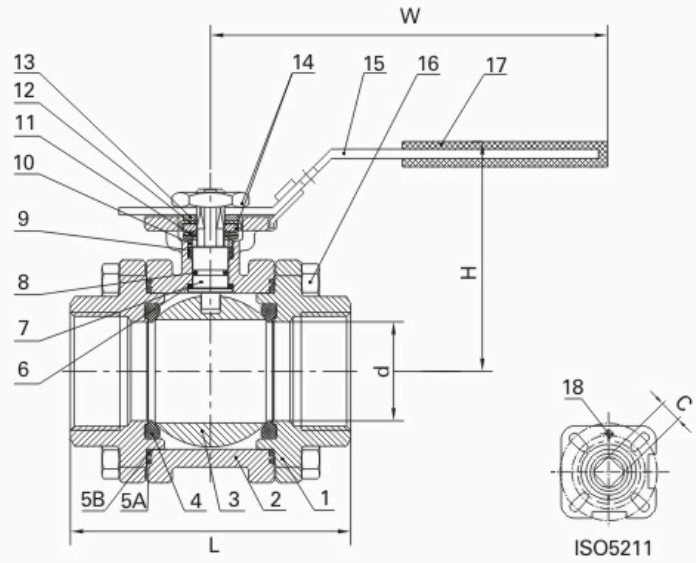

MV-86

- 防火设计
- 口径
- 螺纹标准: ISO, BS, DIN, JIS, ASME
- 长度标准: DIN3202-M3
- 驱动盘标准: ISO5211
- 公称压力: PN125 (2000PSI)
- 工作温度: -25°C~+ 180°C
- 材 料: CF8M, CF8, CF3M, WCB

- Investment casting for body and cap
- Fire-safe design
- Full bore
- Thread: ISO, BS, DIN, JIS, ASME
- Length: DIN 3202-M3
- Mounting pad: ISO5211
- Pressure rating: PN125 (2000PSI)
- Working temperature: -25°C~+ 180°C
- Material: CF8M, CF8, CF3M, WCB

MATERIAL LIST

| ITEM | PARTS | MATERIAL | QTY. |
|------|-------------------|----------|-------|
| 1 | Cap | CF8M | 2 |
| 2 | Body | CF8M | 1 |
| 3 | Ball | SS316 | 1 |
| 4 | Ball Seat | PTFE | 2 |
| 5A | Body Gasket A | PTFE | 2 |
| 5B | Body Gasket B | PTFE | 2 |
| 6 | Thrust Washer | PTFE | 1 |
| 7 | Stem | SS316 | 1 |
| 8 | O-Ring | VITON | 1 |
| 9 | Stem Packing | PTFE | 1 |
| 10 | Stem Ring | SS316 | 1 |
| 11 | Belleville Washer | SS301 | 2 |
| 12 | Nut Stopper | SS304 | 1 |
| 13 | Plate Washer | SS304 | 1 |
| 14 | Nut | SS304 | 2 |
| 15 | Handle | SS304 | 1 |
| 16 | Bolt | SS304 | 8(12) |
| 17 | Handle Cover | PLASTIC | 1 |
| 18 | Stop Pin | SS304 | 1 |

PRESSURE-TEMPERATURE RATING

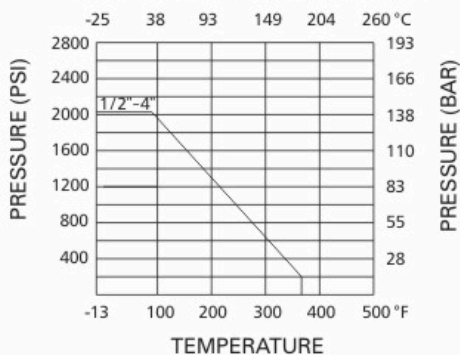

DIMENSION LIST

| SIZE | d | L | H | W | C | ISO5211 | N-m | Kgs |
|--------|-----|-----|-----|-----|----|---------|-----|-------|
| 1/2" | 15 | 75 | 70 | 117 | 9 | F03/F04 | 5 | 0.82 |
| 3/4" | 20 | 80 | 78 | 134 | 11 | F04/F05 | 8 | 1.36 |
| 1" | 25 | 90 | 87 | 134 | 11 | F04/F05 | 10 | 1.83 |
| 1-1/4" | 32 | 110 | 98 | 203 | 14 | F05/F07 | 14 | 3.22 |
| 1-1/2" | 40 | 120 | 104 | 203 | 14 | F05/F07 | 18 | 4.47 |
| 2" | 50 | 140 | 112 | 203 | 14 | F05/F07 | 25 | 6.37 |
| 2-1/2" | 65 | 185 | 140 | 255 | 17 | F07/F10 | 48 | 8.58 |
| 3" | 80 | 205 | 153 | 255 | 17 | F07/F10 | 75 | 13.30 |
| 4" | 100 | 240 | 166 | 302 | 17 | F07/F10 | 110 | 22.30 |