

3-PC BALL VALVE (DIN Length)

三片式球阀 (德标长度)

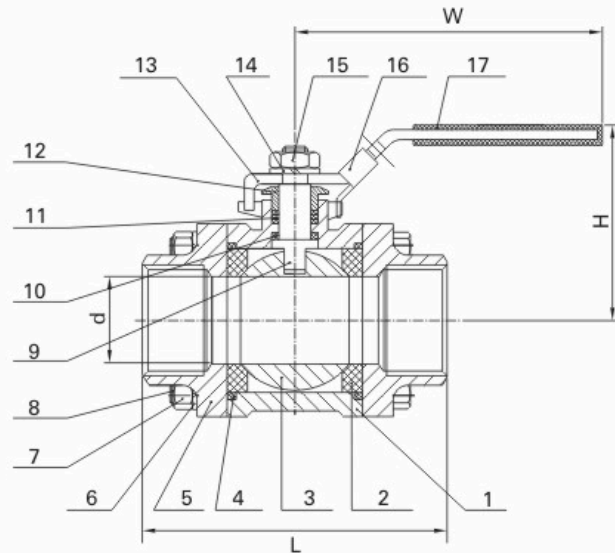
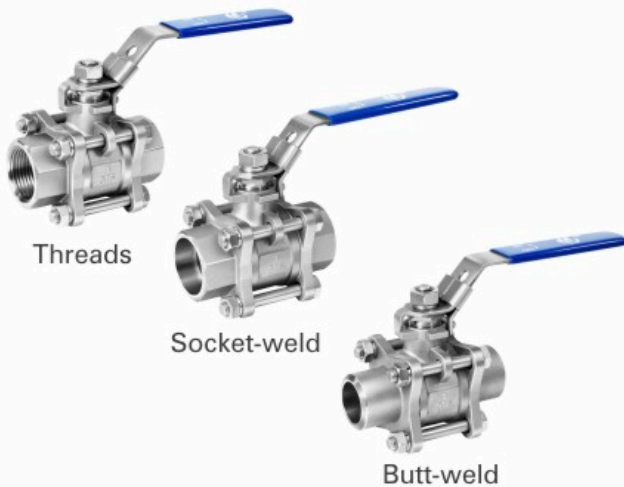

MV-33

- 螺纹标准: ISO, BS, DIN, JIS, ASME
- 长度标准: DIN3202-M3(MV-33/33S)
DIN3202-S13(MV-33B)
- 公称压力: 1000PSI (PN63)
- 工作温度: -25°C~+180°C
- 材 料: CF8M, CF8, CF3M, WCB

- Investment casting for body and cap
- Full bore
- Thread: ISO, BS, DIN, JIS, ASME
- Length: DIN3202-M3(MV-33/33S)
DIN3202-S13(MV-33B)
- Pressure rating: 1000PSI (PN63)
- Working temperature: -25°C~+180°C
- Material: CF8M, CF8, CF3M, WCB

MATERIAL LIST

ITEM	PART	MATERIAL	QTY.
1	Body	CF8M	1
2	Ball Seat	R-PTFE(15%)	2
3	Ball	SS316	1
4	Body Gasket	PTFE	2
5	Cap	CF8M	1
6	Spring Washer	SS304	4(12)
7	Nut	SS304	4(12)
8	Bolt	SS304	4(6)
9	Stem	SS316	1
10	Thrust Washer	PTFE	1
11	Stem Packing	PTFE	1
12	Gland Nut	SS304	1
13	Handle	SS304	1
14	Spring Washer	SS304	1
15	Nut	SS304	1
16	Lock Device	SS304	1
17	Handle Cover	PLASTIC	1

PRESSURE-TEMPERATURE RATING

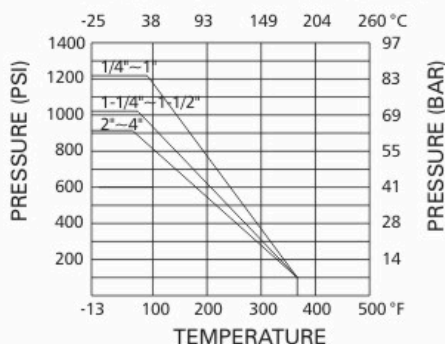

DIMENSION LIST (Threads)

SIZE	d	L	H	W	N-m	Kgs
1/4"	11	50	51	105	4	0.40
3/8"	12.5	60	51	105	4	0.42
1/2"	15	75	53	118	5	0.45
3/4"	20	80	60	118	8	0.73
1"	25	90	75	150	10	1.04
1-1/4"	32	110	80	150	14	1.65
1-1/2"	40	120	88	182	18	2.43
2"	50	140	95	182	25	3.52
2-1/2"	65	185	121	254	48	7.14
3"	80	205	135	254	75	11.85
4"	100	240	158	285	110	20.05