

2-PC BALL VALVE

二片式球阀

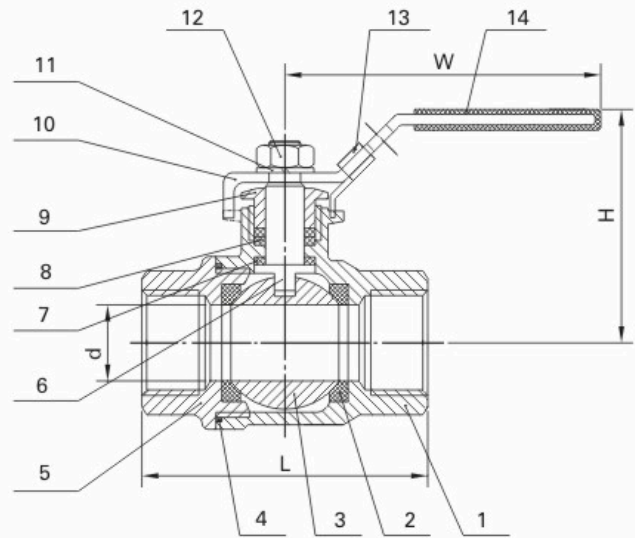

MV-25

- 螺纹标准: ISO, BS, DIN, JIS, ASME
- 公称压力: 1000 PSI (PN63)
- 工作温度: $-25^{\circ}\text{C} \sim +180^{\circ}\text{C}$
- 材 料: CF8M, CF8, CF3M, WCB
- Investment casting for body and cap
- Full bore
- Thread: ISO, BS, DIN, JIS, ASME
- Pressure rating: 1000 PSI (PN63)
- Working temperature: $-25^{\circ}\text{C} \sim +180^{\circ}\text{C}$
- Material: CF8M, CF8, CF3M, WCB

MATERIAL LIST

ITEM	PART	MATERIAL	QTY.
1	Body	CF8M	1
2	Ball Seat	R-PTFE(15%)	2
3	Ball	SS316	1
4	Body Gasket	PTFE	1
5	Cap	CF8M	1
6	Stem	SS316	1
7	Thrust Washer	PTFE	1
8	Stem Packing	PTFE	1
9	Gland Nut	SS304	1
10	Handle	SS304	1
11	Spring Washer	SS304	1
12	Nut	SS304	1
13	Lock Device	SS304	1
14	Handle Cover	PLASTIC	1

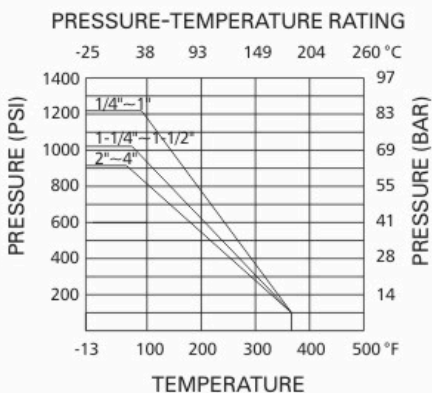

DIMENSION LIST (MV-25)

SIZE	d	L	H	W	N·m	Kgs
1/4"	11.5	49	54	105	4	0.23
3/8"	12.5	49	54	105	4	0.23
1/2"	15	57	56	105	5	0.24
3/4"	20	64	65	118	8	0.45
1"	25	77	70	150	10	0.65
1-1/4"	32	90	75	150	14	1.05
1-1/2"	40	105	93	182	18	1.70
2"	50	125	99	182	25	2.61
2-1/2"	65	153	123	254	48	5.01
3"	76	172	140	254	75	7.61
4"	94	221	175	285	110	14.75